

Symmetrical version

Asymmetrical version

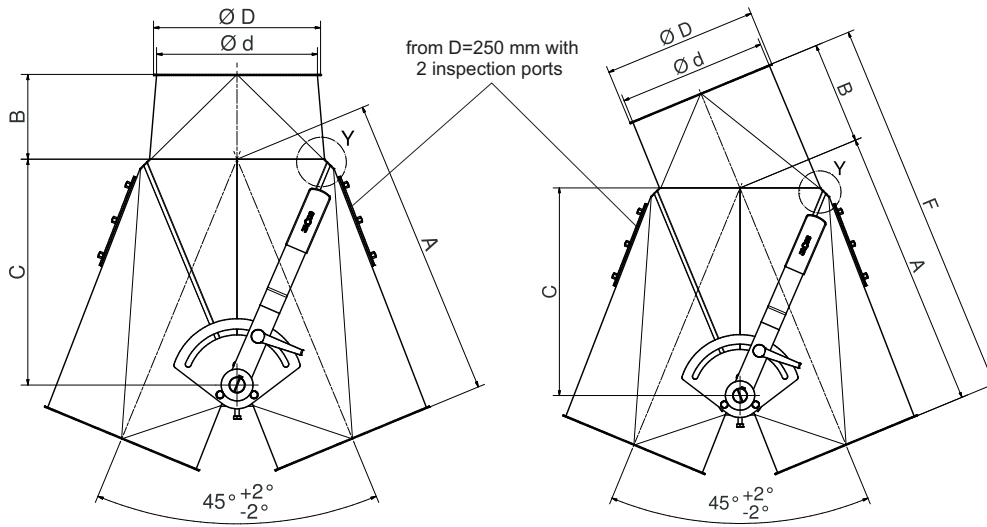

Detail Y

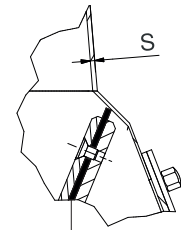

Inner seal made from Silicone

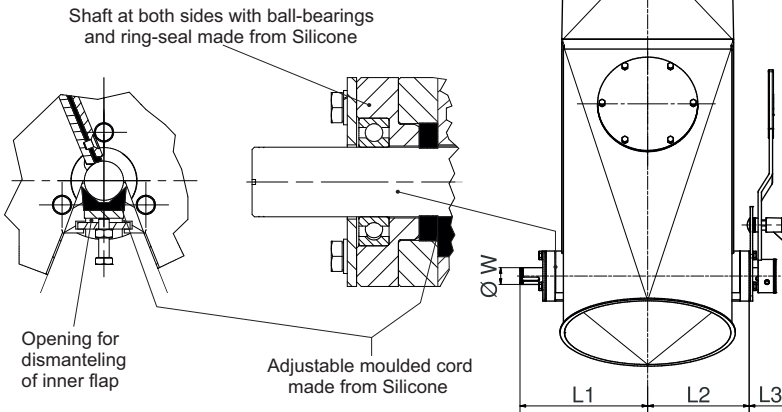

Shaft at both sides with ball-bearings and ring-seal made from Silicone

Opening for dismanteling of inner flap

Adjustable moulded cord made from Silicone

Installing position:

For bulk-goods in respect of the flow characteristics of transported goods in ventilation systems to be chosen free.

Areas of use:

For dust-tight conveying of bulk-goods by gravity and vacuum-conveying in ventilation systems-up to pressure-difference of approx. 0,1 bar.

Please request for special applications.

Pipe diameter tolerance and roundness tolerance to DIN EN 10296-1

Lengths and angles – DIN ISO 2768-1 – Tolerance class V

The article number refers to powder-coated version

Pipe		Ø 100	Ø 120	Ø 150	Ø 175	Ø 200	Ø 250	Ø 300
symmetrical version	Articel-no.	12101518	12121518	12151518	12171518	12201518	12251518	12301518
	A	260	280	315	350	400	480	570
	B	65	70	75	90	105	130	160
	C	165	185	225	255	289	356	426
asymmetrical version	Articel-no.	12101519	12121519	12151519	12171519	12201519	12251519	12301519
	A	260	280	315	350	400	480	570
	B	100	110	115	125	140	170	210
	C	165	185	225	255	289	356	426
	F	360	390	430	475	540	650	780
	Ø d	99	119	149	174	199	249	299
	Ø D	115	135	165	190	215	265	315
	S	2	2	2	2	2	2	2
	Ø W	20	20	20	20	20	30	30
	L1	117	127	142	151	164	205	230
	L2	82	92	107	119	132	160	185
	L3	75	75	75	75	75	75	75
	Weight in kg	7,50	8,60	10,70	13,40	16,35	-	38,00

Denomination:

**Two-way-distributors 45°,
hand-operated**

Date:

06/14

Datasheet-no.

9/16

Rev.

0