

Pipe diameter tolerance and roundness tolerance to DIN EN 10296-1
Lengths and angles – DIN ISO 2768-1 – Tolerance class V

Pipe	Ø 80	Ø 100	Ø 120	Ø 150	Ø 175	Ø 200	Ø 250	Ø
Article-no.	1108*725	1110*725	1112*725	1115*725				-
Ø d	78	100	120	150				-
L	200	200	200	200				-
A	75	75	75	75				-
B	62	72	73	97				-
Weight in kg	0,80	0,90	1,10	1,30				-

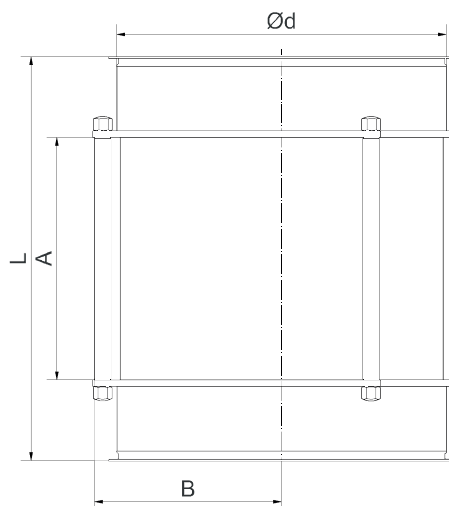

Note:
All plexiglass tubes must always be used without load

* 1=powder-coated, 2=galvanised, 3=stainless steel

Pipe	Ø 80	Ø 100	Ø 120	Ø 150	Ø 175	Ø 200	Ø 250	Ø
Article-no.					1117*725	1120*725	1125*725	-
Ø d					175	200	250	-
L					200	250	250	-
A					100	150	150	-
B					104	117	142	-
Weight in kg					1,50	1,90	2,30	-

Denomination:

Plexiglass pipes with sockets and rod spacers

Date: 04/20

Datasheet-no. 7/6

Rev. 0