

Bends ø60 - ø250 from drawn half shell
Bends ø300 - ø400 from domed segments

Segments: α90° = 3x30°, α60° = 2x30°
α45° = 2x22,5°, α30° = 1x30°

Pipe diameter tolerance and roundness tolerance to DIN EN 10296-1
Lengths and angles – DIN ISO 2768-1 – Tolerance class V

* 1=powder-coated, 2=galvanised, 3=stainless steel

¹⁾ Also available in 1mm thickness

		30°			45°			60°			90°		
60	Article-no.	1106*343	-	-	1106*344	-	-	1106*346	-	-	1106*349	-	-
	Ø d	57	-	-	57	-	-	57	-	-	57	-	-
	Ø D	72	-	-	72	-	-	72	-	-	72	-	-
	S	1,5	-	-	1,5	-	-	1,5	-	-	1,5	-	-
	R	2D			2D			2D			2D		
Weight in kg	0,25	-	-	0,40	-	-	0,50	-	-	0,75	-	-	
80	Article-no.	1108*343	1208*343	-	1108*344	1208*344	-	1108*346	1208*346	-	1108*349	1208*349	-
	Ø d	78	76	-	78	76	-	78	76	-	78	76	-
	Ø D	92	92	-	92	92	-	92	92	-	92	92	-
	S	1	2	-	1	2	-	1	2	-	1	2	-
	R	2D			2D			2D			2D		
Weight in kg	0,20	0,35	-	0,25	0,50	-	0,35	0,65	-	0,50	0,95	-	
100	Article-no.	1110*343	1210*343	-	1110*344	1210*344	-	1110*346	1210*346	-	1110*349	1210*349	-
	Ø d	100	99	-	100	99	-	100	99	-	100	99	-
	Ø D	114	115	-	114	115	-	114	115	-	114	115	-
	S	1	2	-	1	2	-	1	2	-	1	2	-
	R	2D			2D			2D			2D		
Weight in kg	0,30	0,60	-	0,45	0,85	-	0,55	1,10	-	0,80	1,55	-	
120	Article-no.	1112*343	1212*343	13121343	1112*344	1212*344	13121344	1112*346	1212*346	13121346	1112*349	1212*349	13121349
	Ø d	119,5	119	118	119,5	119	118	119,5	119	118	119,5	119	118
	Ø D	134,5	135	136	134,5	135	136	134,5	135	136	134,5	135	136
	S	1,5 ¹⁾	2	3	1,5 ¹⁾	2	3	1,5 ¹⁾	2	3	1,5 ¹⁾	2	3
	R	2D			2D			2D			2D		
Weight in kg	0,45	0,80	1,30	0,60	1,15	1,85	0,75	1,50	2,45	1,20	2,20	3,60	
140	Article-no.	1114*343	1214*343	-	1114*344	1214*344	-	1114*346	1214*346	-	1114*349	1214*349	-
	Ø d	135,5	135	-	135,5	135	-	135,5	135	-	135,5	135	-
	Ø D	150,5	151	-	150,5	151	-	150,5	151	-	150,5	151	-
	S	1,5 ¹⁾	2	-	1,5 ¹⁾	2	-	1,5 ¹⁾	2	-	1,5 ¹⁾	2	-
	R	2D			2D			2D			2D		
Weight in kg	0,55	1,00	-	0,80	1,45	-	1,00	2,05	-	1,50	3,05	-	

Denomination:

Bends R=2D

Date: 03/20

Datasheet-no. 4/3/1

Rev. 1

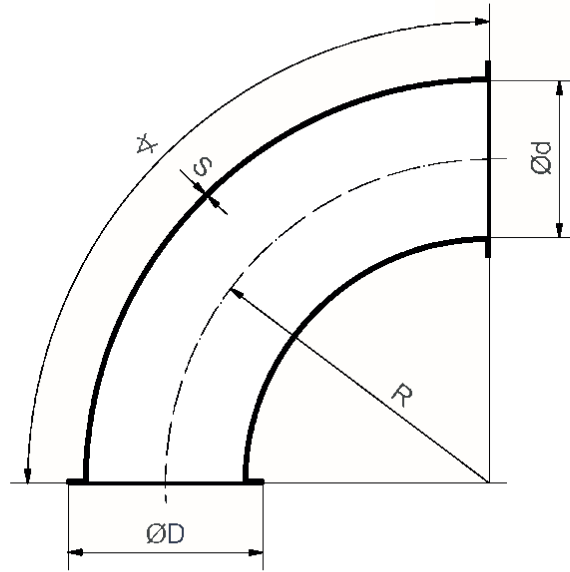

Bends ø60 - ø250 from drawn half shell
Bends ø300 - ø400 from domed segments

Segments: α90° = 3x30°, α60° = 2x30°
α45° = 2x22,5°, α30° = 1x30°

Pipe diameter tolerance and roundness tolerance to DIN EN 10296-1

Lengths and angles – DIN ISO 2768-1 – Tolerance class V

* 1=powder-coated, 2=galvanisedt, 3=stainless steel

¹⁾ Also available in 1mm thickness

		30°			45°			60°			90°		
Ø 150	Article-no.	1115*343	1215*343	13151343	1115*344	1215*344	13151344	1115*346	1215*346	13151346	1115*349	1215*349	13151349
	Ø d	149,5	149	148	149,5	149	148	149,5	149	148	149,5	149	148
	Ø D	164,5	165	166	164,5	165	166	164	165	166	164,5	165	166
	S	1,5 ¹⁾	2	3	1,5	2	3	1,5 ¹⁾	2	3	1,5 ¹⁾	2	3
	R	2D			2D			2D			2D		
Weight in kg	0,65	1,25	1,85	0,95	1,80	2,60	1,20	2,40	3,60	1,75	3,50	5,30	
Ø 175	Article-no.	1117*343	1217*343	13171343	1117*344	1217*344	13171344	1117*346	1217*346	13171346	1117*349	1217*349	13171349
	Ø d	174,5	174	173	174,5	174	173	174,5	174	173	174,5	174	173
	Ø D	189,5	190	191	189,5	190	191	189,5	190	191	189,5	190	191
	S	1,5	2	3	1,5 ¹⁾	2	3	1,5	2	3	1,5	2	3
	R	2D			2D			2D			2D		
Weight in kg	0,80	1,65	2,50	1,25	2,25	3,70	1,50	3,15	4,70	2,35	4,60	7,20	
Ø 200	Article-no.	1120*343	1220*343	13201343	1120*344	1220*344	13201344	1120*346	1220*346	13201346	1120*349	1220*349	13201349
	Ø d	199,5	199	198	199,5	199	198	199,5	199	198	199,5	199	198
	Ø D	214,5	215	216	214,5	215	216	214,5	215	216	214,5	215	216
	S	1,5	2	3	1,5	2	3	1,5	2	3	1,5	2	3
	R	2D			2D			2D			2D		
Weight in kg	1,00	2,10	3,30	1,50	3,00	4,60	2,20	4,10	6,38	3,00	6,10	9,00	
Ø 224	Article-no.	1122*343	1222*343	-	1122*344	1222*344	-	1122*346	1222*346	-	1122*349	1222*349	-
	Ø d	219,5	220	-	219,5	219	-	219,5	219	-	219,5	219	-
	Ø D	234,5	235	-	234,5	235	-	234,5	235	-	234,5	235	-
	S	1,5	2	-	1,5	2	-	1,5	2	-	1,5	2	-
	R	2D			2D			2D			2D		
Weight in kg	2,03	2,65	-	3,00	3,90	-	3,96	5,20	-	5,89	7,80	-	
Ø 250	Article-no.	1125*343	1225*343	13251343	1125*344	1225*344	1325*344	1125*346	1225*346	13251346	1125*349	1225*349	13251349
	Ø d	249,5	249	248	249,5	249	248	249,5	249	248	249,5	249	248
	Ø D	264,5	265	266	264,5	265	266	264,5	265	266	264,5	265	266
	S	1,5	2	3	1,5	2	3	1,5	2	3	1,5	2	3
	R	2D			2D			2D			2D		
Weight in kg	1,70	3,50	5,00	2,50	4,80	7,30	3,60	6,90	10,10	4,80	9,70	14,20	

Denomination:

Bends R=2D

Date: 03/20

Datasheet-no. 4/3/1

Rev. 1

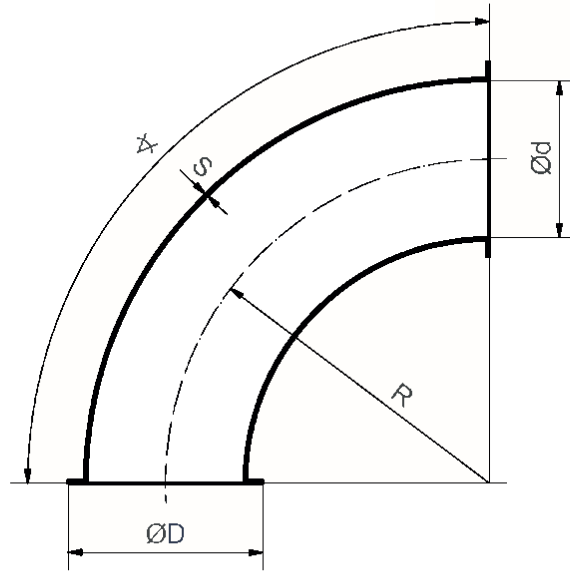

Bends $\varnothing 60$ - $\varnothing 250$ from drawn half shell
 Bends $\varnothing 300$ - $\varnothing 400$ from domed segments
 Segments: $\alpha 90^\circ = 3 \times 30^\circ$, $\alpha 60^\circ = 2 \times 30^\circ$
 $\alpha 45^\circ = 2 \times 22,5^\circ$, $\alpha 30^\circ = 1 \times 30^\circ$

Pipe diameter tolerance and roundness tolerance to DIN EN 10296-1
 Lengths and angles – DIN ISO 2768-1 – Tolerance class V
 * 1=powder-coated, 2=galvanised, 3=stainless steel

¹⁾ Also available in 1mm thickness

		30°			45°			60°			90°		
Ø 300	Article-no.	1130*343	1230*343	13301343	1130*344	1230*344	13301344	1130*346	1230*346	13301346	1130*349	1230*349	13301349
	Ø d	299,5	299	298	299,5	299	298	299,5	299	298	299,5	299	298
	Ø D	314,5	315	316	314,5	315	316	314,5	315	316	314,5	315	316
	S	1,5	2	3	1,5	2	3	1,5	2	3	1,5	2	3
	R	2D			2D			2D			2D		
Weight in kg	3,70	4,60	6,90	5,10	7,20	11,20	7,00	9,30	13,80	10,10	13,50	20,50	
Ø 350	Article-no.	-	1235*343	13351343	-	1235*344	13351344	-	1235*346	13351346	-	1235*349	13351349
	Ø d	-	349	348	-	349	348	-	349	348	-	349	348
	Ø D	-	365	366	-	365	366	-	365	366	-	365	366
	S	-	2	3	-	2	3	-	2	3	-	2	3
	R	2D			2D			2D			2D		
Weight in kg	-	6,35	9,52	-	9,80	14,30	-	13,00	19,05	-	19,60	29,00	
Ø 400	Article-no.	-	1240*343	13401343	-	1240*344	13401344	-	1240*346	13401346	-	1240*349	13401349
	Ø d	-	398	396	-	398	396	-	398	396	-	398	396
	Ø D	-	414	414	-	414	414	-	414	414	-	414	414
	S	-	2	3	-	2	3	-	2	3	-	2	3
	R	2D			2D			2D			2D		
Weight in kg	-	8,50	12,70	-	12,70	19,00	-	16,90	25,30	-	25,00	31,00	

Denomination:

Bends R=2D

Date: 03/20

Datasheet-no. 4/3/1

Rev. 1